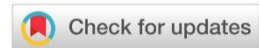

Research Paper

Performance and Fuel Consumption of Diesel Engine Fueled by Diesel Fuel and Waste Plastic Oil Blends: An Experimental Investigation

Sunaryo¹, Priyo Adi Sesotyo², Eqwar Saputra³, Agus Pulung Sasmito⁴¹Department of Mechanical Engineering, Universitas Sains Al-Qur'an, 56351, Indonesia²Department of Electrical Engineering, Universitas Semarang, 50196, Indonesia³Department of Mechanical Engineering, Universitas Muhammadiyah Purwokerto, 53182, Indonesia⁴Department of Mining & Materials Engineering, McGill University, H3A 2T5, Canada

✉ sunaryo@unsiq.ac.id

🌐 <https://doi.org/10.31603/ae.3692>

Published by Automotive Laboratory of Universitas Muhammadiyah Magelang collaboration with Association of Indonesian Vocational Educators (AIVE)

Article Info

Submitted:

22/05/2020

Revised:

21/11/2020

Accepted:

24/11/2020

Online first:

30/12/2020

Abstract

This study analyzes the performance of the diesel engine in terms of power, torque, specific fuel consumption, and thermal efficiency using diesel and pyrolysis oil. The waste plastic oil (WPO) used in this research was produced through a pyrolysis process using raw materials from Low-density Polyethylene (LDPE) mixed with diesel fuel in volume ratios WPO10, WPO20, WPO30, WPO40, and WPO50. In addition, a performance test was carried out on the single-cylinder diesel engine test bench. The results showed that performing the diesel engine with the addition of WPO increased the average power and torque by 5% and 3%, thereby producing a higher heating value. Furthermore, the concentration of WPO also reduces the level of specific fuel consumption to be more efficient, with a decrease in thermal efficiency. In conclusion, plastic waste pyrolysis oil is a promising alternative fuel applicable to a diesel engine.

Keywords: Pyrolysis, Waste plastic oil; Engine performance; Thermal efficiency; Specific fuel consumption

Abstrak

Penelitian ini menganalisis performansi mesin diesel yang meliputi daya, torsi, konsumsi bahan bakar spesifik, dan efisiensi thermal dengan bahan bakar minyak diesel dengan minyak hasil pirolisis sampah plastik. Limbah plastik minyak (WPO) diproduksi melalui proses pirolisis menggunakan bahan baku dari plastik Low-density Polyethylene (LDPE) dan dicampur dengan minyak diesel dengan perbandingan volume WPO10, WPO20, WPO30, WPO40, dan WPO50. Uji kinerja dilakukan pada test bench mesin diesel satu silinder. Hasil penelitian menunjukkan bahwa performansi mesin diesel dengan penambahan WPO meningkat dengan daya rata-rata 5% dan torsi 3%, untuk nilai kalor semakin tinggi. Konsentrasi WPO juga akan menurunkan tingkat konsumsi bahan bakar spesifik menjadi lebih efisien, namun akan terjadi penurunan efisiensi termal. Hasil ini menyatakan bahwa minyak pirolisis limbah plastik merupakan bahan bakar alternatif yang menjanjikan untuk diaplikasikan pada mesin diesel.

Kata-kata kunci: Pirolisis, Limbah minyak plastik; Performa mesin; Efisiensi termal; Konsumsi bahan bakar spesifik

1. Introduction

The significant increase in the use of diesel engines for diverse light and heavy purposes such as transporting agricultural tractors, air

compressors, and power plants has tremendously increased in communities. Furthermore the advantages of using a diesel engine in various sectors are relatively due to its high fuel efficiency,



This work is licensed under a Creative Commons Attribution-NonCommercial 4.0 International License.

durability, and cost-effectiveness [1],[2]. In some countries, the ratio of the use of a diesel engine to gasoline is approximately 7: 1 [3]. Therefore, the need for diesel fuel is significant, thereby making it necessary to seek alternative means.

The need for fuel energy tends to increase globally due to the current limited supply of fossil fuel [4]. Furthermore, fossil fuel's high possibility to explode also makes it necessary to seek alternative fuels for the internal combustion engine (ICE). Therefore, studies on specific compression ignition (CI) engines need to be carried out to continuously determine an alternative fuel suitable for many applications [2]. According to recent studies, one of the smart ways to fully use waste to meet the increasing energy demands is converting plastic waste into valuable plastic base material from petroleum, which has a high calorific value [5],[6].

The potential for plastic waste as an alternative energy source is abundant. Furthermore plastics play a significant role in the construction, healthcare, electronics, automotive, and packaging fields [7]. Its use in various sectors of life ultimately increases the amount of waste. Over the past three decades, plastic production in significant economies has faced explosive growth, reaching an average of 129 million tonnes per year [8]. In 2018, global plastic production reached 360 million tons, which significantly increased compared to the 279 million tons obtained in 2011 [9],[10]. This is a significant problem in society due to its ability to cause environmental pollution. The process of turning plastic into fuel for vehicles and industry is considered environmentally friendly [11],[12].

This technology also uses a gasification system, one of which is the pyrolysis method. Plastic waste is burned under a vacuum in a closed vessel where the gas formed is condensed into fuel oil [5]. Cracking plastic waste is usually carried out at high temperatures ranging from 400 to 700 °C without oxygen [13], for 3 to 4 hours, and produces 75% liquid hydrocarbon [14]. The derived liquid fraction comprises various C₆ - C₁₆ hydrocarbons in abundance [15], with a high concentration of alkanes and aromatic compounds [16], identical to diesel fuel and gasoline. During the pyrolysis process, the plastic oil produced was predominantly diesel, 72% fuel oil, 17% kerosene, and 11% gasoline [17]. The

plastic pyrolysis process is useful and feasible as an alternative approach to recycling raw materials for plastic waste [18].

Several studies have been carried out regarding the properties and use of plastic oil as fuel for engines. For instance, plastic oil's physicochemical properties were found to be in ASTM standards with a higher kinematic viscosity and less carbon and sulfur residues [19],[20]. Furthermore, the heating values ranging from 41 to 46 MJ/kg, with density of 0.7 to 0.9 kg/m³ [17],[21]. The effect of using a mixture of pyrolysis plastic oil on a diesel engine shows that at full-load conditions, the pressure in the cylinder, rate, and the heat becomes higher than the diesel [19]. The volumetric efficiency decreases with an increase in brake thermal and mechanical efficiencies [22]. The effect of using a plastic oil mixture to reduce the level of exhaust gas emissions is lower [17], with a decrease in diesel engines and emissions in the form of NO_x, smoke, carbon monoxide, and hydrocarbons [14]. Also, the amount of smoke levels of liquid plastic fuel is 19.73% compared to diesel, at 29.67% [23].

Several preliminary studies have been conducted to determine using waste plastic oil as an alternative to a diesel engine. However, this study analyzes engine performance, thermal efficiency, and specific fuel consumption in single cylinder direct injection diesel engines with varying engine load used to determine the effect.

2. Materials and Method

The material used in this research is waste plastic oil (WPO) with Low-density Polyethylene (LDPE). WPO is mixed with diesel fuel in ratios of WPO10 (10% WPO and 90% diesel), WPO20 (20% WPO and 80% diesel), WPO30 (30% WPO and 70% diesel), WPO40 (40% WPO and 60% diesel), and WPO50 (50% WPO and 50% diesel). The fuel mixing results were determined by conducting a property test covering calorific value and density. Furthermore, an engine performance test was carried out on a 1 cylinder diesel engine with a capacity of 462 cc for all WPO blends to determine the type of hydro brake.

The pyrolysis method comprising of preparing plastic waste from the LDPE type, chopping, washing, and drying was used to transform the plastic waste into fuel, as shown in [Figure 1](#). The plastic material is put into the pyrolysis reactor at

a temperature of 400 °C in a room without oxygen. The gas emitted from the reactor is condensed and used to turn plastic into oil. The uncondensed gas is extracted with a small amount of char left in the reactor.

The performance test scheme for a diesel engine is carried out to determine the influence of using WPO mixture on power, torque, thermal efficiency, and specific engine fuel consumption, as shown in Figure 2. The observations results of force meter, fuel consumption time, property testing of calorific value, and fuel density are used to measure the diesel engine's power, torque, and thermal efficiency. Table 1 shows the engine specifications used in the research.

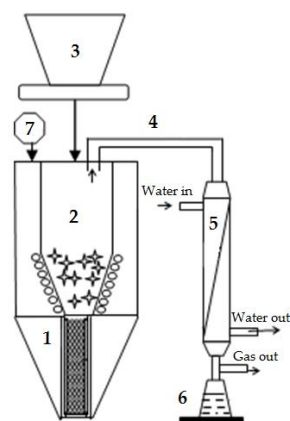
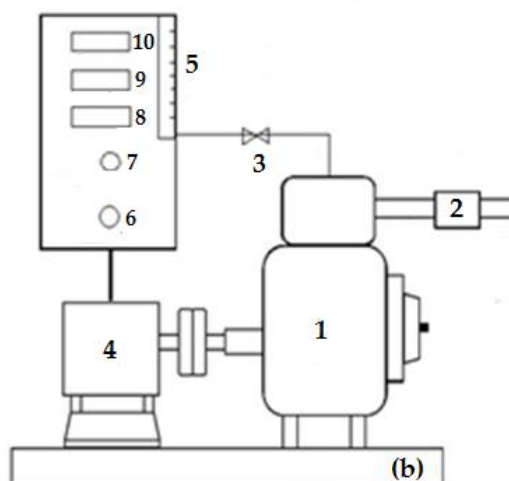

Figure 1. Plastic pyrolysis equipment schematic: (1) Furnace; (2) Reactor; (3) Hopper; (4) Pipe); (5) Condenser; (6) Oil can; and (7) Thermometer



1. Diesel engine; 2. Exhaust pipe; 3. Fuel valve; 4. Hydro-brake; 5. Measurement glass; 6. Load valve; 7. Engine switch; 8. Engine speed; 9. Temperature; and 10. Force-meter

Figure 2. Schematic model of the experimental setup: (a) Diesel engine test bench, and (b) Schematic model of measurement

Table 1. Test engine specification

Parameter	Specification
Engine type	Diesel LC178F (D), 4 Strokes single-cylinder, direct injection
Displacement (L)	349 cc
Bore x stroke (mm)	78 x 73 mm
Compression ratio	21: 1
Power max	4.5 kW at 3000 rpm
Cooling system	Water cooling system
Lubricating system	Forced system
Fuel supply temperature	18° ± 1 °C

3. Result and Discussion

3.1. Physicochemical Characteristics

The property characteristics of WPO and diesel fuel are shown in Table 2. Pyrolysis products from LDPE plastics are a series of light and heavy hydrocarbons from the lowest carbon atomic number (C₄-C₅) to the highest (> C₂₀) and diesel fuel (C₁₆-C₂₀) [24]. The physicochemical properties of WPO are identical to Diesel fuel oil because both are made from crude oil.

3.2. Diesel Engine Performance Test

The comparison of the amount of engine power and torque of each of the WPO10, WPO20, WPO30, WPO40, WPO50, and diesel fuel uses are shown in Figure 3 and Figure 4. Furthermore, a graphical approach is used to analyze engine power trends. At loads below 60%, pure diesel fuel is still better than the mixing fuel. The test shows that the mixing of WPO and diesel fuel decreases in power from 0 to 60%, while at 80%, the power increases by 5%. Meanwhile, at full load, the diesel engine power uses fuel of 2.41 kW

with a mixture of 2.53 kW WPO at an engine speed of 2035 rpm. This shows that engine power increases with a rise in load due to the increasing amount of fuel maintained at a constant speed. High calorific value plays a significant role in producing engine power [24].

Mixing pure diesel fuel and WPO affects engine torque. Figure 4 shows the relationship between engine torque and load. The engine torque increases with a rise in load from zero to full. This occurs due to the augmentation of mechanical torque losses.

The mixture of WPO with pure diesel fuel increased engine torque, especially at the loading above 50%. While the largest torque of 12.34 Nm is generated in WPO10 compared to 11.30 Nm in pure diesel. The engine torque of all WPO blends competes with pure diesel fuel due to the lack of enormous differences between the torque values. The mean torque shown on the curve is slightly higher than pure diesel fuel, which is 3% only. The primary reason for this increase in torque is because the heating value of WPO is slightly higher than pure diesel.

Table 2. Properties of diesel fuel and WPO

Properties	Unit	Fuel Type	
		Diesel fuel	WPO
Caloric value	MJ/kg	45.10	45.77
Density	g/ml	0.8254	0.7611
Viscosity Cinematic	mm ² /s	3.785	0.967
Flash Point	°C	< 17	< 11
Specific gravity		0.8531	0.791
Cetane index		48	51
Sulfur content	%	0.046	0.032

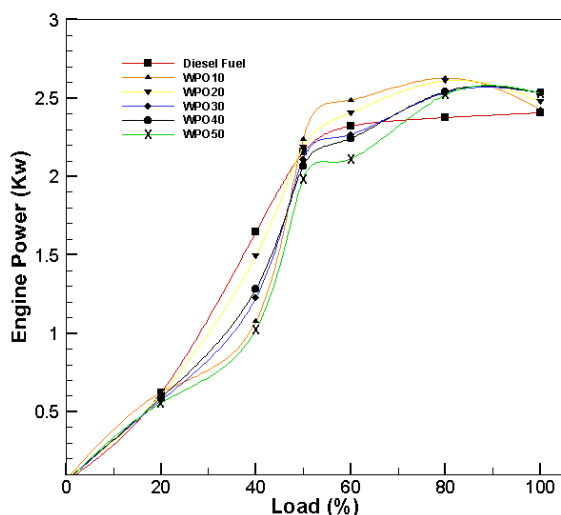

Figure 3. Engine load versus engine power

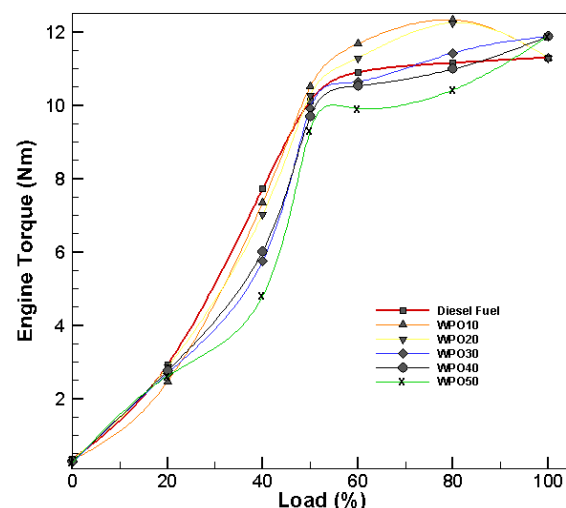

Figure 4. Engine load versus engine torque

3.3. BSFC Test

Brake specific fuel consumption (BSFC) is the ratio between the engine's mass of fuel and the power generated during a certain time. The BSFC value is dependent on the power generated by the engine, while the specific fuel consumption is an indicator of the effects used to produce power. The smaller the specific fuel consumption, the more efficient the engine. Figure 5 shows the specific fuel consumption levels of various types of WPO-diesel fuel blends.

Physiochemical properties of fuels, such as density, kinematic viscosity, and calorific value, affect the brake specific fuel capacity (BSFC). Figure 5 shows that BSFC is higher than diesel fuel at no-load and low-load conditions with a value of 0.1667 kg/kWh, while the average for all WPO mixtures is 0.1314 kg/kWh. The increase in BSFC at low loads is due to the rise in the concentration of aromatic hydrocarbons, which increases viscosity. This results in an imprecise air-fuel mixture (AFR) ratio, especially during poor mix operation. A steady increase in load decreases the BSFC value in both diesel fuel and all WPO blends. At full load operation, the addition of the WPO shows an increasingly economical level of fuel consumption with an average of 0.0137 kg/kWh, which is 15% lower than diesel fuel. At higher loads, all fuels show a lower BSFC [25].

3.4. Thermal Efficiency Test

The calculations results for thermal brake efficiency (BTE) at all loads using diesel fuel and WPO is shown in Figure 6. The figure indicates that at no-load conditions, BTE for diesel is 0.28%, while WPO10, WPO20, WPO40, and WPO50 are 0.21%, 0.24%, 0.19%, and 0.17%, respectively. At low loads, atomization of the PO mixed fuel particles is difficult, therefore, the thermal brake efficiency is lower. Higher BTE was observed under part and full-load conditions, with an increase in PO concentration, which is for better preparation of the air-fuel mixture at higher loads. An increase in load leads to a rise in all fuel mixtures and a trend of thermal brake efficiency.

At full load operation, diesel fuel is proven to produce the highest BTE compared to WPO blends by 34.38% while WPO10, WPO20, WPO30, WPO40 and WPO50 are 33.77%, 31.46%, 32.24%, 32.35%, and 32.55%. This is in line with the research carried out by Ventakasen et al. [19],

which stated that the higher the cylinder temperature produced by PO mixtures, the greater the heating value and heat loss to the surroundings during combustion. Also, an enormous amount of heat energy is used to destroy aliphatic and aromatic hydrocarbons in the WPO concentration [26].

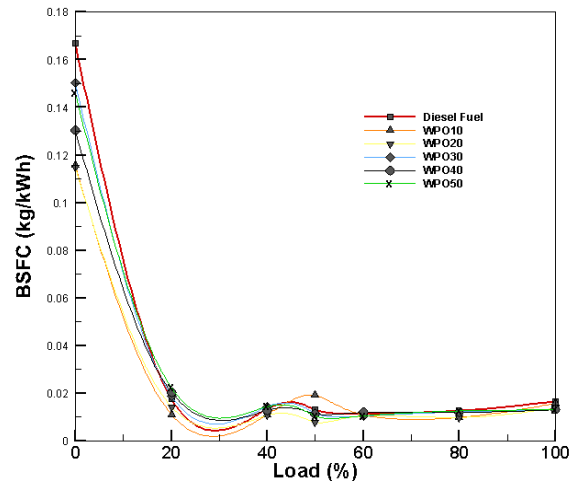

Figure 5. Engine load versus BSFC

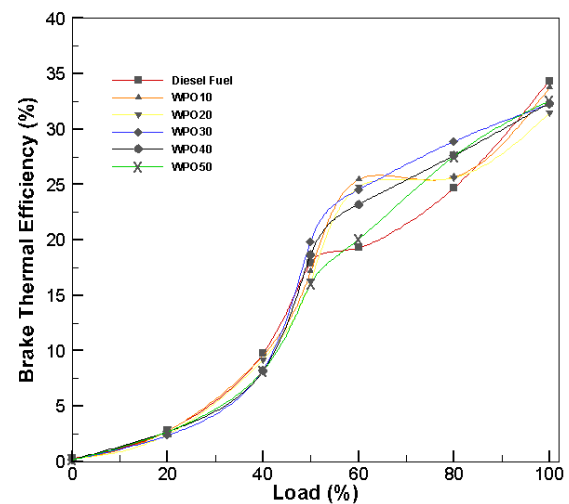

Figure 6. Engine Load versus Thermal Efficiency

4. Conclusion

This experimental investigation was carried out to analyze and understand the physicochemical characteristics of fuel and the diesel engine performance at zero to full load in seven categories. The physicochemical characteristics of waste plastic oil are identical to those of diesel fuel and higher for caloric and cetane number. On average, the WPO-diesel fuel ratio shows an increase in engine power and torque by 5% and 3%. WPO reduces the level of fuel consumption (BSFC) by 15% at full load,

although diesel is more economical. An increase in engine load leads to a rise in thermal brake efficiency. At zero load, diesel fuel produces better thermal efficiency, while at full load, WPO shows an increase in thermal efficiency. Therefore, WPO is suitable as an alternative fuel in diesel engines with continued research to improve its quality, both in terms of the process and the addition of additives.

Acknowledgment

The authors are grateful to the Mechanical Engineering Laboratory of the UNSIQ Mechanical Engineering Department, Wonosobo, and the Petroleum, Gas, and Coal Technology Laboratory of the UGM Chemical Engineering Department, Yogyakarta, for their support and assistance.

Author's Declaration

Authors' contributions and responsibilities

The authors made substantial contributions to the conception and design of the study. The authors took responsibility for data analysis, interpretation and discussion of results. The authors read and approved the final manuscript.

Funding

No funding information from the authors.

Availability of data and materials

All data are available from the authors.

Competing interests

The authors declare no competing interest.

Additional information

No additional information from the authors.

References

- [1] W. Tutak, K. Lukács, S. Szwaja, and Á. Bereczky. "Alcohol – diesel fuel combustion in the compression ignition engine." *Fuel*. 0016-2361. 2015.
- [2] P. Behera and S. Murugan. "Combustion, performance and emission parameters of used transformer oil and its diesel blends in a DI diesel engine." *Fuel*. vol. 104. pp. 147–154. 2013.
- [3] N. S. Patel and K. D. Desai. "Waste Plastic Oil As A Diesel Fuel In The Diesel Engine: A Review." *International Journal of Engineering Research & Technology (IJERT)*. vol. 2. no. 3. pp. 2–7. 2013.
- [4] G. E. Tverberg. "Oil supply limits and the continuing financial crisis." *Energy*. vol. 37. pp. 27–34. 2012.
- [5] R. Kumar, M. K. Mishra, S. K. Singh, and A. Kumar. "Experimental evaluation of waste plastic oil and its blends on a single-cylinder diesel engine." *Journal of Mechanical Science and Technology*. vol. 30. no. 10. pp. 4781–4782. 2016.
- [6] M. Eswaramoorthi, T. Venkateshan, M. Bala, and S. Gejendhiran. "Review of Plastic Waste Management by Pyrolysis." *International Journal for Research in Applied Science & Engineering Technology (IJRASET)*. vol. 4. no. XI. pp. 514–517. 2016.
- [7] A. Sharuddin, F. Abnisa, W. Daud, and M. Karoua. "Pyrolysis of plastic waste for liquid fuel production as a prospective energy resource." *IOP Conference Series: Materials Science and Engineering 334(012001)*. 2018.
- [8] I. Kalargaris, G. Tian, and S. Gu. "Combustion, performance and emission analysis of a DI diesel engine using plastic pyrolysis oil." *Fuel Processing Technology*. vol. 157. pp. 108–115. 2017.
- [9] Association of Plastic Manufacturers Europe. "Plastics – the Facts 2019. An analysis of European plastics production, demand and waste data." European Association of Plastics Recycling and Recovery Organisations. German. 2019.
- [10] I. Kalargaris, G. Tian, and S. Gu. "The utilization of oils produced from plastic waste at different pyrolysis temperatures in a DI diesel engine." *Energy*. vol. 131. pp. 179–185. 2017.
- [11] D. Iswadi, F. Nurisa, and E. Liastuti. "Pemanfaatan Sampah Plastik LDPE dan PET Menjadi Bahan Bakar Minyak dengan Proses Pirolisis." *Jurnal Ilmu Teknik Kimia UNPAM*. vol. 1. no. 2. 2017.
- [12] A. K. Panda, R. K. Singh, and D. K. Mishra. "Thermolysis of waste plastics to liquid fuel A suitable method for plastic waste management and manufacture of value-added products – A world perspective."

- Renewable and Sustainable Energy Reviews*. vol. 14. pp. 233–248. 2010.
- [13] A. Adrados. I. De Marco. B. M. Caballero. A. López. M. F. Laresgoiti. and A. Torres. "Pyrolysis of plastic packaging waste: A comparison of plastic residuals from material recovery facilities with simulated plastic waste." *Waste Management*.. vol. 32. no. 5. pp. 826–832. 2012.
- [14] M. Mani. G. Nagarajan. and S. Sampath. "An experimental investigation on a DI diesel engine using waste plastic oil with exhaust gas recirculation." *Fuel*. vol. 89. no. 8. pp. 1826–1832. 2010.
- [15] K. G. I. Ahmad. M. Ismail Khan. Hizbullah Khan. M. Ishaq. Razia Tariq and & Waqas Ahmad. "Pyrolysis Study of Polypropylene and Polyethylene into Premium Oil Products." *International Journal Green Energy*. no. December. pp. 37–41. 2014.
- [16] P. T. Williams and E. Slaney. "Analysis of products from the pyrolysis and liquefaction of single plastics and waste plastic mixtures." *Resources Conservation Recycling Analysis*.. vol. 51. pp. 754–769. 2007.
- [17] Sunaryo. M. Efendy. Sarjito. N. S. Kamarrudin. "Pyrolysis of Plastic Waste as an Alternative Fuels in Spark Ignition Engine." *International Journal of Emerging Trends in Engineering Research*.. vol. 7. no. 11. pp. 454–459. 2019.
- [18] M. Nahid and H. Hamid. "Pyrolysis of mixed plastics for the recovery of useful products." *Fuel Processing Technology*.. vol. 90. no. 4. pp. 545–552. 2009.
- [19] H. Venkatesan. S. Sivamani. K. Bhutoria. and H. H. Vora. "Experimental study on combustion and performance characteristics in a DI CI engine fuelled with blends of waste plastic oil." *Alexandria Engineering Journal*.. pp. 4–10. 2017.
- [20] N. Miskolczi. L. Bartha. G. Deak. B. Jover. and D. Kallo. "Thermal and thermo-catalytic degradation of high-density polyethylene waste." *Journal of Analytical and Applied Pyrolysis*. vol. 72. pp. 235–242. 2004.
- [21] T. J. Anup and V. Watwe. "Waste Plastic Pyrolysis Oil as Alternative For SI and CI Engines." *International Journal of Innovative Research in Science. Engineering and Technology*.. vol. 3. no. 7. pp. 14680–14687. 2014.
- [22] N. Gomathi and R. Pl. "Study On the Performance of Plastic Waste Oil in CI Engines: A Review." *Research Journal of Pharmaceutical Biological and Chemical Sciences*. vol. 7. no. 6. pp. 1689–1696. 2016.
- [23] A. S. D. Afiati. A. Amrullah. A. Syarief. and R. Siswanto. "Characteristics of Synthetic Fuel from Plastic Waste by Gasification Method." *International Journal of Scientific & Technology Research*. vol. 3. no. 3. pp. 293–296. 2014.
- [24] N. Pratama and H. Saptoadi. "Characteristics of Waste Plastics Pyrolytic Oil and Its Applications as Alternative Fuel on Four Cylinder Diesel Engines." *Journal of Renewable Energy Development*.. vol. 3. no. 1. pp. 13–20. 2014.
- [25] V. Hariram and M. Ismail. "Combustion performance and emission analysis of tire pyrolysis oil - Diesel blends in a single-cylinder direct injection compression ignition engine." *Research Journal of Pharmaceutical. Biological and Chemical Sciences*. vol. 6. no. 2. pp. 1657–1665. 2015.
- [26] D. C. Rakopoulos. E. G. Giakoumis. R. G. Papagiannakis. and D. C. Kyritsis. "Influence of properties of various common bio-fuels on the combustion and emission characteristics of high-speed DI (direct injection) diesel engine: Vegetable oil. bio-diesel. ethanol. n-butanol. diethyl ether." *Energy*. vol. 73. pp. 354–366. 2014.